



Power Meter Monitor

Business and Mission-

Critical Solutions Provider

PV Tracker Gateway PMM Tracking Solutions

Data Sheet



Model: PMM1103G

Document: Data Sheet

Document version: 1.0

Date: October 2022



COPYRIGHT NOTICE

The information in this document is subject to change without prior notice to improve reliability, design, and function and does not represent a commitment on the part of the manufacturer.

In no event will the manufacturer be liable for direct, indirect, special, incidental, or consequential damage arising out of the use or inability to use the product or documentation, even if advised of the possibility of such damages.

This document contains proprietary information protected by copyright. All rights are reserved. No part of this manual may be reproduced by any mechanical, electronic, or other means in any form without prior written permission of the manufacturer.

TRADEMARKS

All registered trademarks and product names mentioned herein are used for identification purposes only and may be trademarks and/or registered trademarks of their respective owners.

AMI is a trademark of American Megatrends Inc.

Intel & Atom are trademarks of Intel Corporation

IBM, PC/AT, PS/2&VGA are trademarks of International Business Machines Corporation
Microsoft Windows is a trademark of Microsoft Corp. RTL is the trademark of Realtek Semiconductor Co., Ltd.

DECLARATION OF CONFORMITY

This restriction is subject to protect the operational process of the system in the business environment, which will produce, use, and transmit radiofrequency energy. Harmful interference to radio communication could result if instructions to the correct installation and usage were not applied. The interference prevention cannot be guaranteed even with proper installation according to the manual. If the device causes a bad effect on the radio / TV signal. The user could preclude that by turning the device on/off.

When this device produces some harmful interference, the user can use the following measure to solve the interference problem:

1-Setting the receiving antenna's direction or location to increase the distance between this device and receiver.

2-Plug in the device's power connector into different circuits of the power outlet with the receiver.

3-If any technical support is needed, the dealer or experienced radio/TV technical personnel must be informed.

TECHNICAL SUPPORT AND SERVICE

Visit Pmm-usa.us to browse FAQs and get further details.

User should collect the following information before submitting technical support and service requests:

- Product name, model and serial number.
- Installed software (operating system, OS version, installed applications and so on).
- Full description of the problem
- Detailed information about every error.

SAFETY INSTRUCTIONS

- Only trained and qualified personnel can install, operate, or maintain the device.
- Before starting the installation, all safety precautions must be read, and warning labels affixed to the device must be observed. Doing so protects the device from damage and ensures your safety.
- Safety precautions provided in this document may not cover all safety aspects, note to always remain mindful of safety.
- PMM is not liable for any consequence that results from violation of regulations pertaining to safe operations or safety codes pertaining to design, production, and equipment usage.
- DO NOT use liquids or decontamination spray to clean the device surface and assure that it is totally disconnected while cleaning.
- Take all measures to prevent device drop before or during installation.
- Prior to connecting the device to power source, ensure the source and device voltage and power are 100% matched.
- Keep the cables in a suitable covered place.
- If the device is not used for a long time, shut off the power to avoid the damages by transient overvoltage.
- DO NOT allow any liquid flow into the device; to avoid fire or short circuit.
- The recommended storage temperature range should NOT be less than 30°C OR higher than 85°C.



Warning:

- Read the power source and device inlet carefully.
- Handle device with both hands.
- Clean and maintain the device using recommended, safe and suitable methods.



Caution:

If any unauthorized changes of settings or repairs are done without PMM approval; then user's rights of controlling this device will be canceled.



Contents

| | |
|--------------------------------------|---|
| KEY FEATURES | 4 |
| DESCRIPTION | 4 |
| APPLICATIONS | 4 |
| CONNECTION DIAGRAM..... | 5 |
| TECHNICAL SPECIFICATIONS..... | 6 |
| ENCLOSURE ASSEMBLY INFORMATION | 7 |
| ENCLOSURE DIMENSIONS | 8 |

KEY FEATURES

- Intelligence designed around high precision solar tracking needs
- Controlling up to two trackers simultaneously
- Compatible with any tracking system
- Built to meet all harsh environment and Power substation requirements
- Wide range of power supply options
- -40 to 85°C (-40 to 185°F) system operating temperature
- Compact size with fanless design
- Wide range of mounting options

DESCRIPTION

Tracker-mounted photovoltaic and solar thermal installations' efficiency and profitability greatly depend on how precisely the receiving units are directed at the sun; as a result, tracking control intelligence is essential to maximizing energy and profit return.

PMM1103G- gateway transmits the signal to the controller either through Modbus RS485, or Wi-Fi or LoRa then PMM1103 controller adjusts the angle of the trackers to the optimal angle which maximize the production. In addition, PMM1103G- receives signals from the position tracking sensor to be updated on cloud SCADA allowing for operator to easily monitor the tracker position through Web or mobile application.

Note: Refer to [PMM1103C- Single Axis Tracker Controller](#) for more details.

PMM1103 gateway is a rugged powerful reliable fanless Linux based embedded industrial computer, powered by Allwinner H3 CPU, which offers high-performance processing with a high degree of functional integration.

Moreover, PMM1103 gateway is covered by a durable metal chassis which was designed and tested on the field to withstand shock, vibration, extended temperature ranges and challenging elements of a harsh environment. It is especially designed to meet all power substations and PV plants requirements.

APPLICATIONS

- Single axis PV.
- Concentration PV (CPV).
- High-concentration PV (HCPV).
- Solar-thermal.
- Concentration solar-thermal.

CONNECTION DIAGRAM

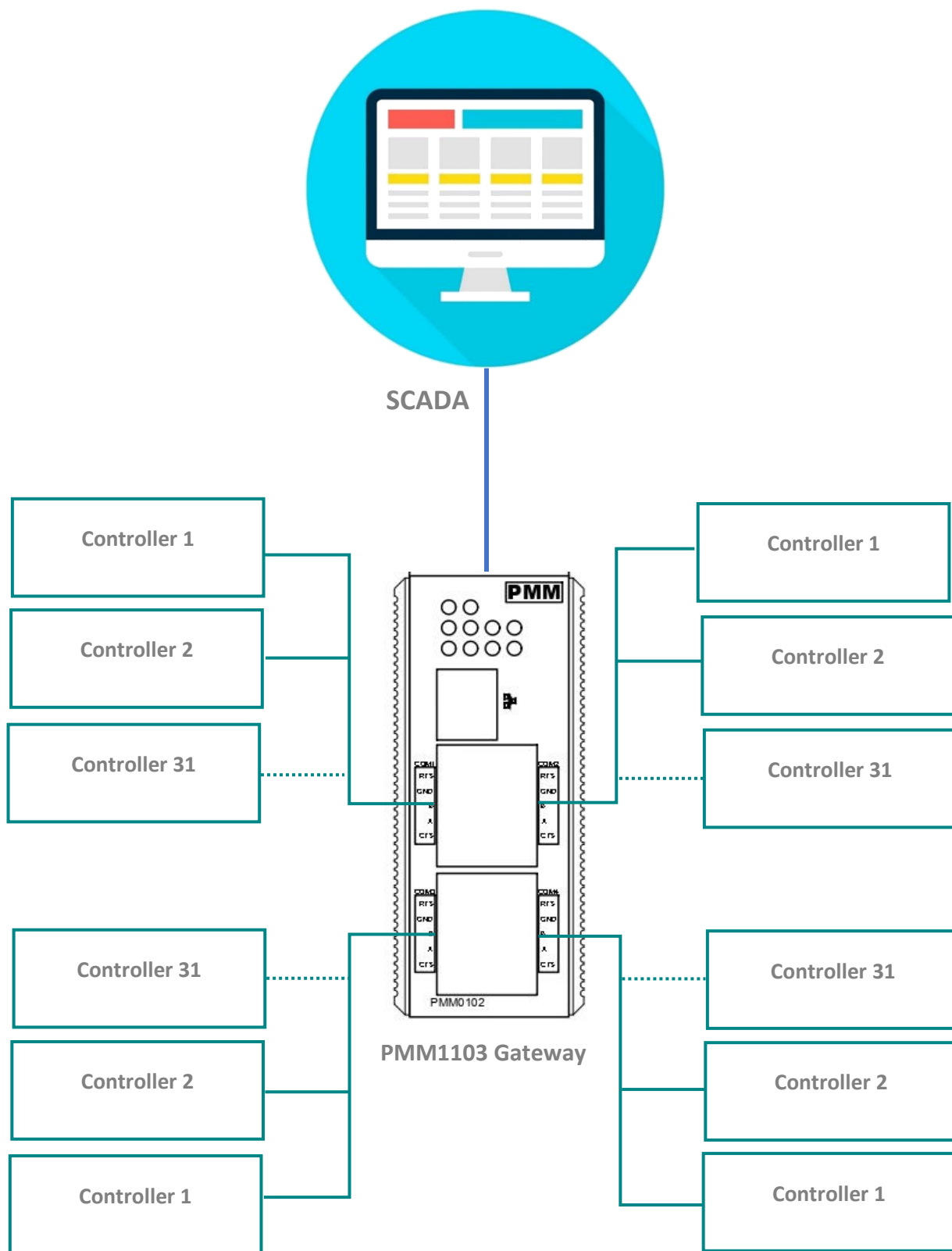

Note: the connection between PMM1103 gateway and the controllers can be: Modbus RTU (2 wires), or Wi-Fi or LoRa.

TECHNICAL SPECIFICATIONS

Computer Interface

| | |
|--------------------|---|
| Ethernet | 2x 10/100Base-T RJ45 |
| USB | 1x USB2.0 Type A 2x Micro USB |
| Wi-Fi | 2.4 GHz |
| Serial | 1x RS485 |
| Optional Interface | 16 pin connectors on edge with following connectivity options (max 3 options can be chosen upon order to be factory pre-fitted) RS232 RS485 RS422 CAN bus Analogue Inputs Analogue Output Digital Inputs Digital Output |
| SD Slot | 1x MicroSD card socket for user supplied card up to 64GB |

Power Parameters

| | |
|----------------------|---|
| Power Supply Options | 10-56 VDC 8-40 VAC 36-72 VDC 25-50 VAC 85-285 VAC / 100-300 VDC |
| Power Connector | Phoenix Contact 4pins 3.5mm |

Physical Characteristics

| | |
|------------------|--|
| Housing | Metal |
| Dimensions | 4 x 4 x 1.75 inch (103 x 103 x 44 mm) |
| Mounting Options | Standard 35mm DIN Rail Direct Panel Mounting Front Panel Mounting 19" rack 1U |
| Certifications | RoHS, CE and FCC |

ENCLOSURE ASSEMBLY INFORMATION

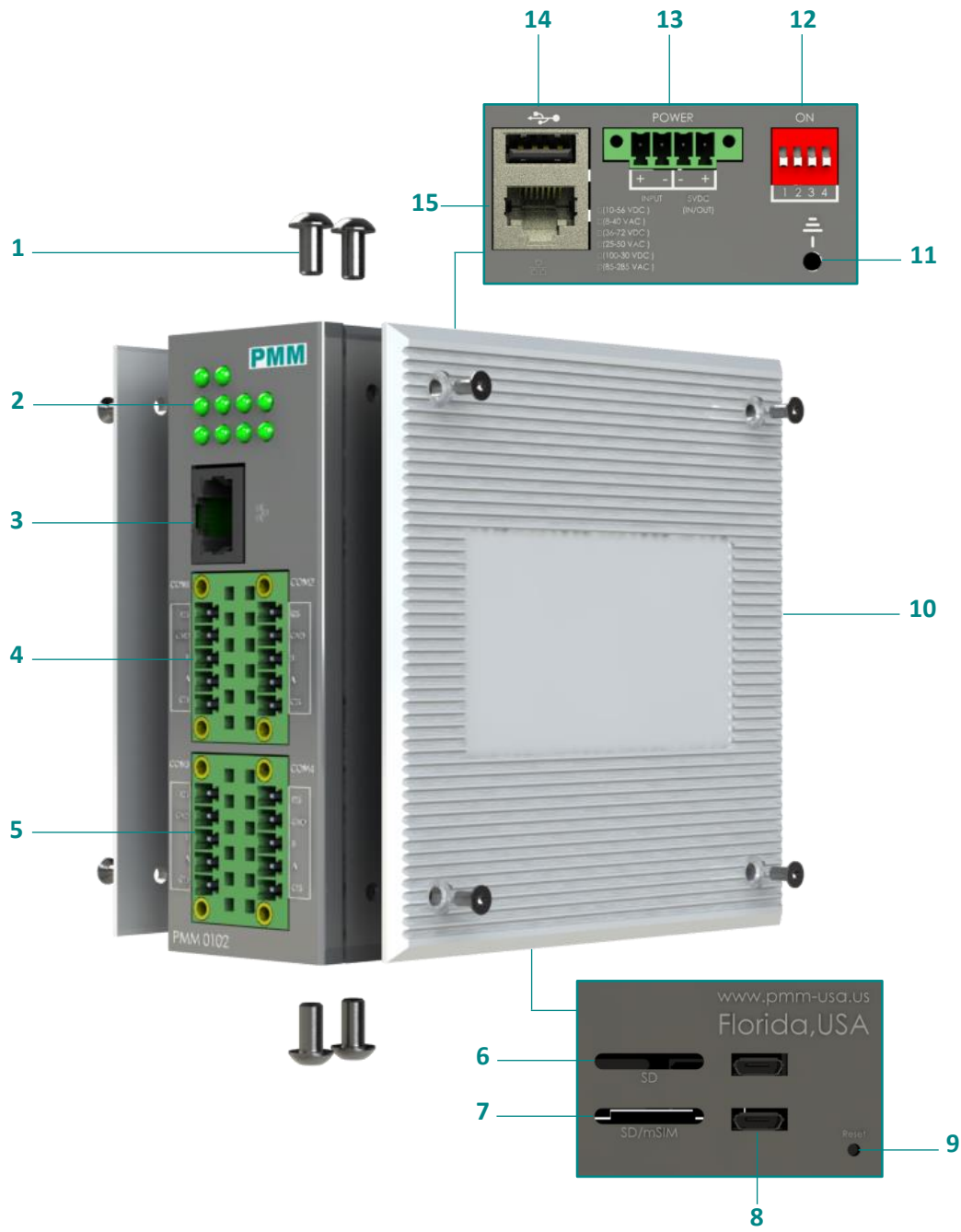

| ITEM | DESCRIPTION |
|------|------------------------|
| 1 | Screws |
| 2 | 10x LED Indicators |
| 3 | Ethernet port |
| 4 | 2x Communication Ports |
| 5 | 2x Communication Ports |
| 6 | SD card slot |
| 7 | SD/mSIM card slot |

| | |
|----|--------------------|
| 8 | 2x Micro USB ports |
| 9 | Reset button |
| 10 | Heat Sink |
| 11 | Earth |
| 12 | DIP Switch |
| 13 | Power Adapter |
| 14 | USB Type A Port |
| 15 | Ethernet port |

ORDERING INFORMATION

| Order Configuration table | | | | | | |
|--|----|-------|-------|-------|---------------------------|--------------------------|
| PMM1103 Gateway | -x | -09xx | -09xx | -09xx | Table1* Comm port options | |
| Power supply | | | | | COM Ports Options | |
| 10-56 VDC | -1 | | | | Analog input | PMM0901 |
| 8-40 VAC | -2 | | | | Analog output | PMM0902 |
| 36-72 VDC | -3 | | | | CANBUS (UART) | PMM0910 |
| 25-50 VAC | -4 | | | | CANBUS (UART) | PMM0910i |
| 85-285 VAC/100-300 VDC | -5 | | | | CANBUS (SPI) | PMM00911 |
| COM Port 1 | | | | | CANBUS (SPI) | PMM0911i |
| RS485 | | -0912 | | | RS485 | PMM0912 |
| CAN Bus | | -0910 | | | RS422 | PMM0913 |
| ANALOG INPUTS | | -0901 | | | RS422 | PMM0914 |
| DIGITAL INPUT | | -0920 | | | RS232 | PMM0915 |
| GSM/GPRS | | -0917 | | | LTE | PMM0916 |
| <i>See the COM Ports table for more options</i> | | | | | | |
| COM Port 2 (Same as COM Port 1 options) | | | -09xx | | Digital input | PMM0920 |
| COM Port 3 (Same as COM Port 1&2 options) | | | | -09xx | Digital output | PMM0921 |

Accessories

| | |
|------------------------------|---------------------------|
| DIN Mount (included) | DIN Rail Mounting Bracket |
| Wall Mounting Kit (included) | 2x Wall Mounting Bracket |
| Panel Mounting Kit(optional) | 2x Panel Mounting Bracket |
| Rack Mounting Kit (optional) | Rack Mounting Bracket |

CONTACT INFORMATION:

For direct inquiries or any customized orders, contact us on sales@Pmm-usa.us